

SK200 is currently not fitted as standard.
It will be fitted for future options.

The darker shading shows the
outline of the chassis.

%R150 (10Ω) is fitted only when the
T856 is used in a Series I rack frame
(refer to Part I for full details).

T856 PCB Layout - Top Side
220-01397-01

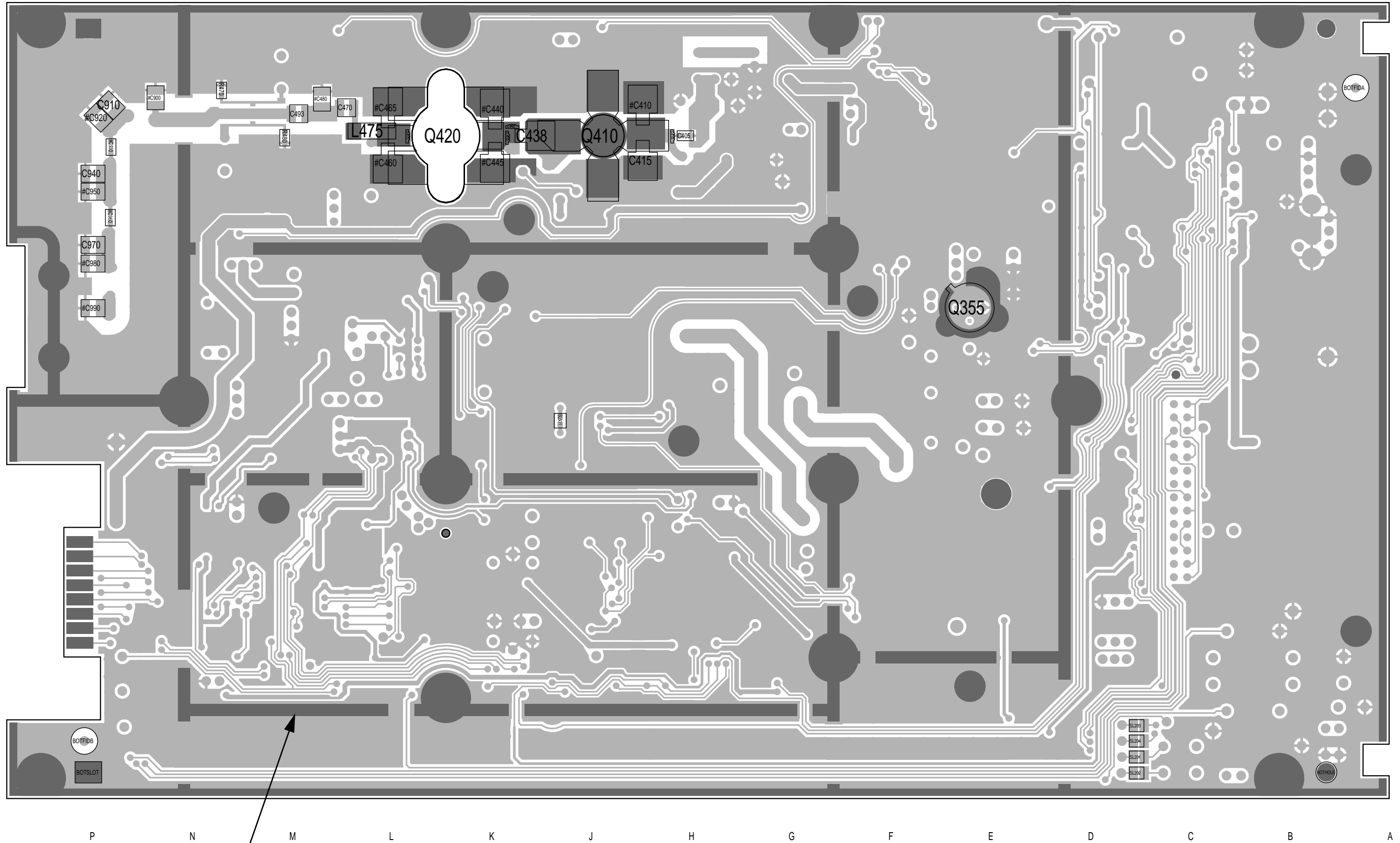

The darker shading shows the footprint of the bottom cover.

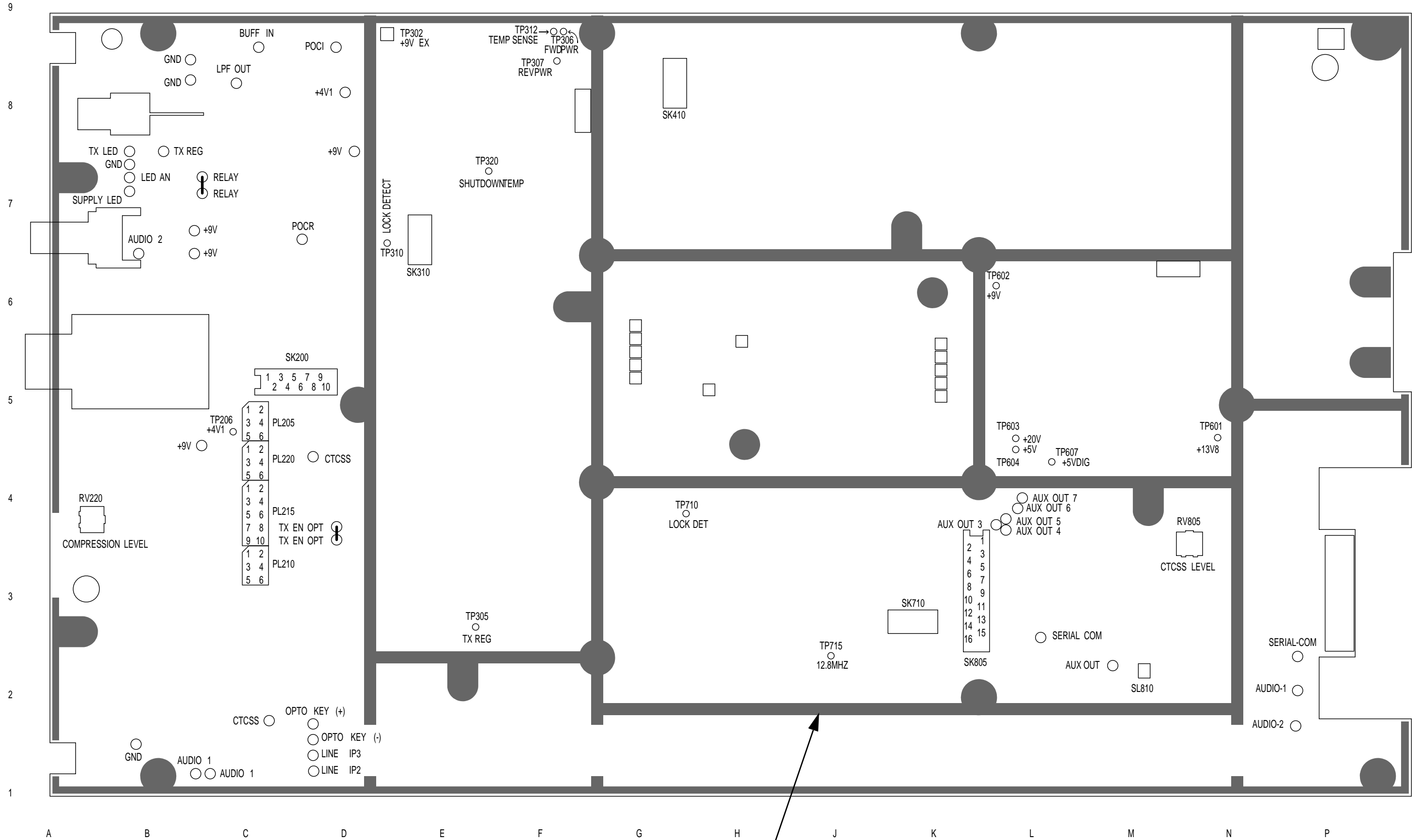

The darker shading shows the outline of the chassis.

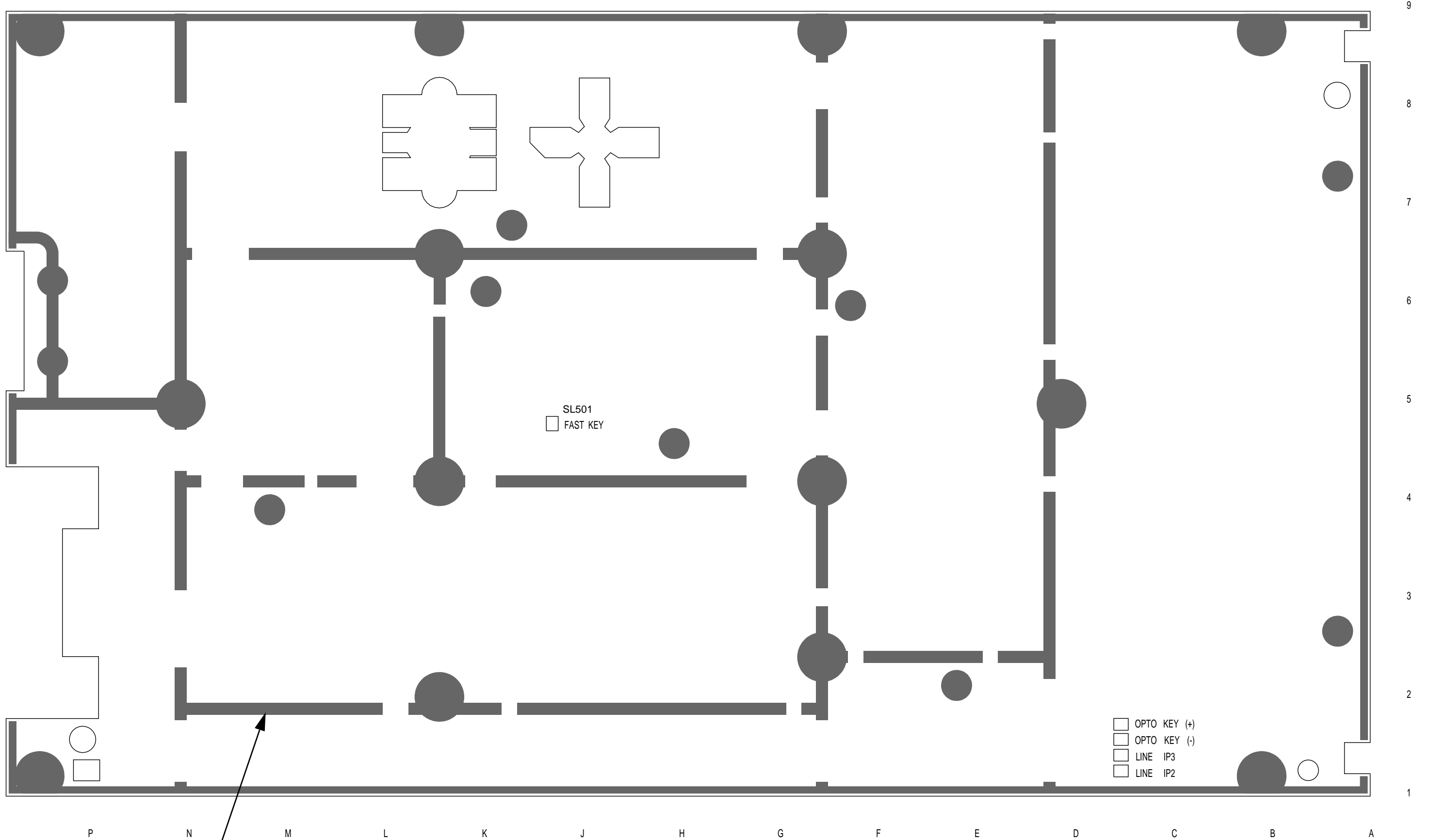

The darker shading shows the footprint of the bottom cover.

T856 Test Points & Options Connections - Bottom Side
220-01397-01

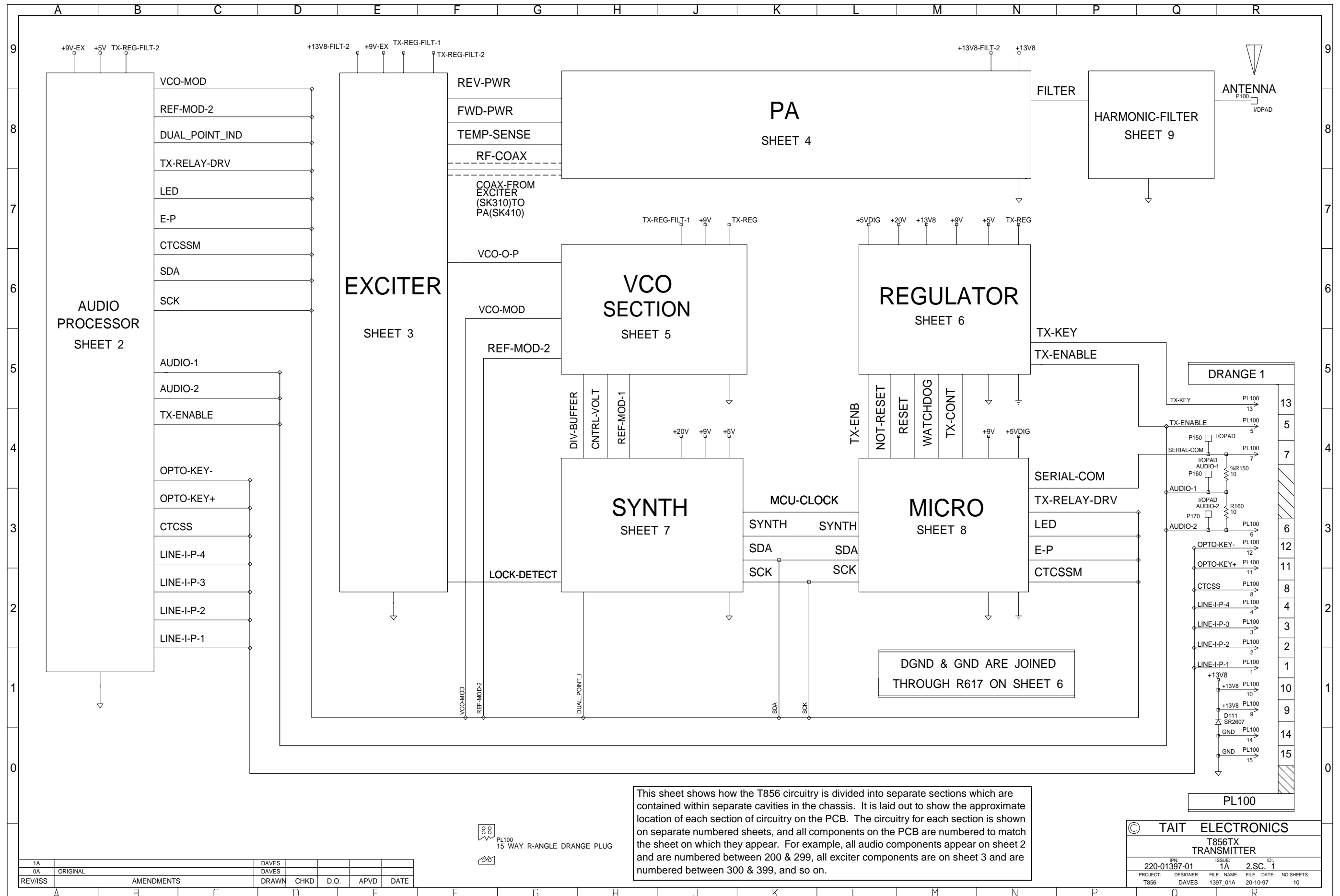

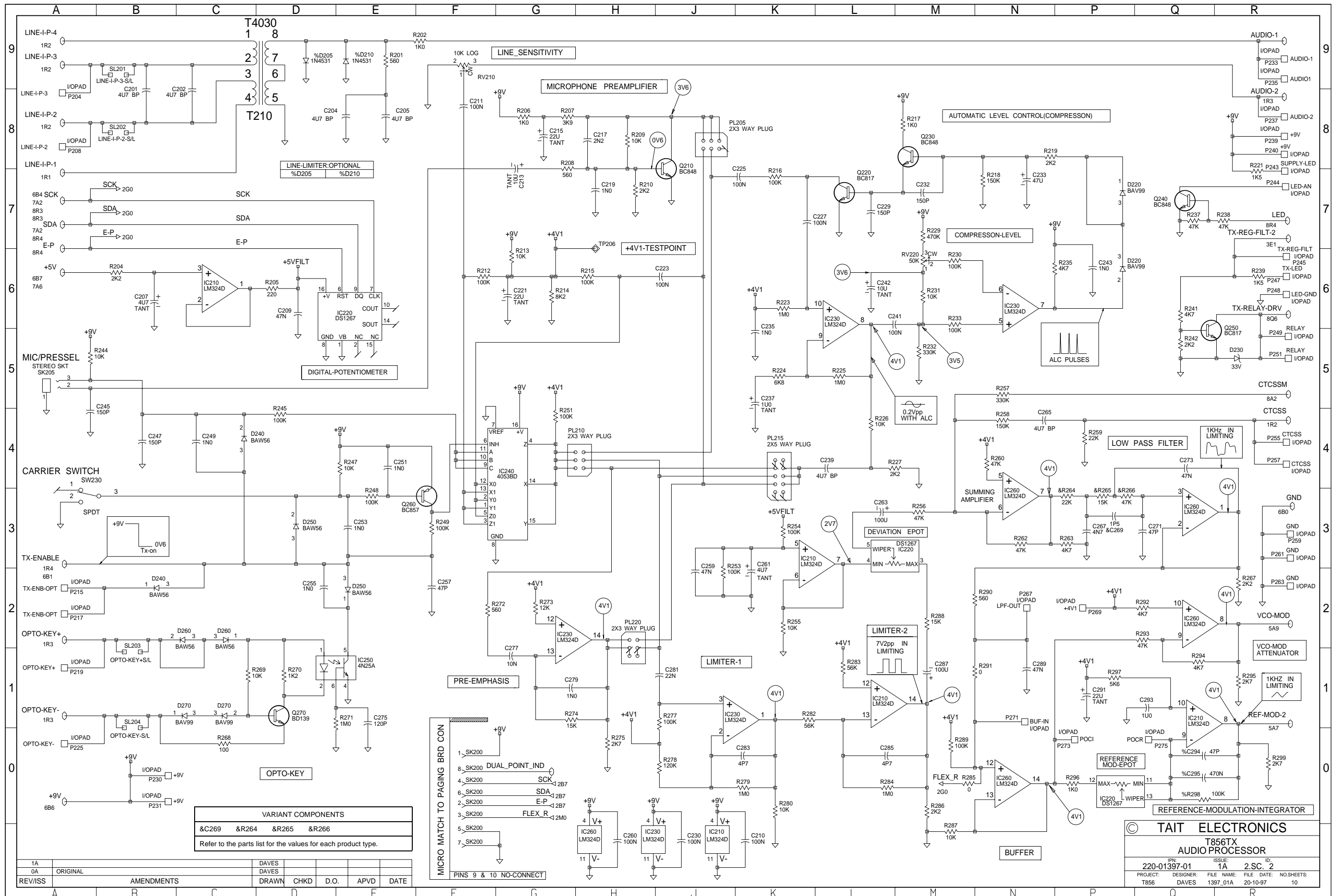

REV/ISS	AMENDMENTS	DRAWN	CHKD	D.O.	APVD	DATE
1A	ORIGINAL	DAVES				
0A		DAVES				

VARIANT COMPONENTS			
&C269	&R264	&R265	&R266
Refer to the parts list for the values for each product type.			

© TAIT ELECTRONICS
T856TX
AUDIO PROCESSOR

IPN	ISSUE	ID
220-01397-01	1A	2.S.C. 2
PROJECT:	DESIGNER:	FILE NAME:
T856	DAVES	1397_01A
		FILE DATE:
		20-10-97
		NO.SHEETS:
		10

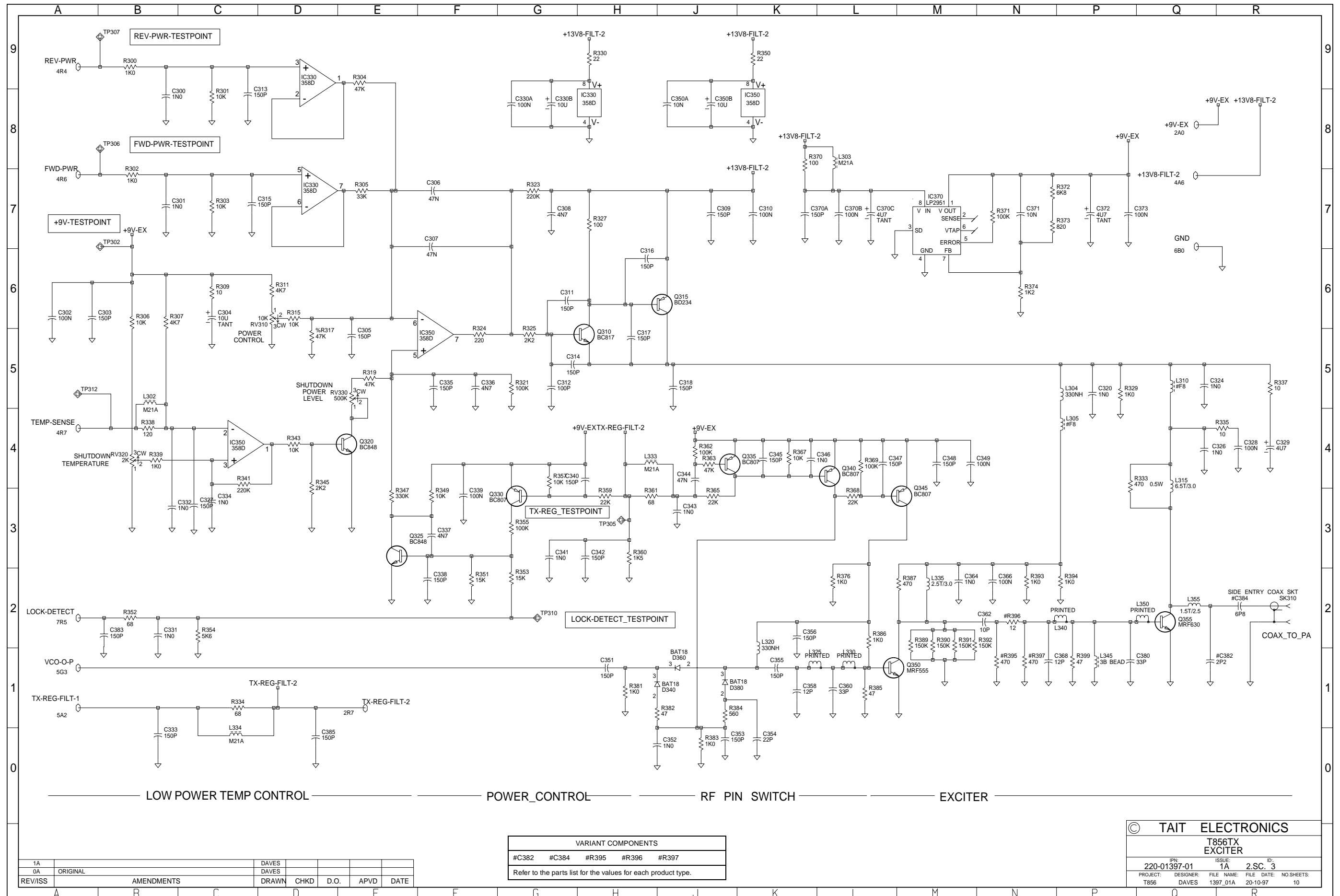

© TAIT ELECTRONICS
T856TX
EXCITER
IPN: 220-01397-01
ISSUE: 1A
ID: 2.S.C. 3
PROJECT: T856
DESIGNER: DAVES
FILE NAME: 1397_01A
DATE: 20-10-97
NO SHEETS: 10

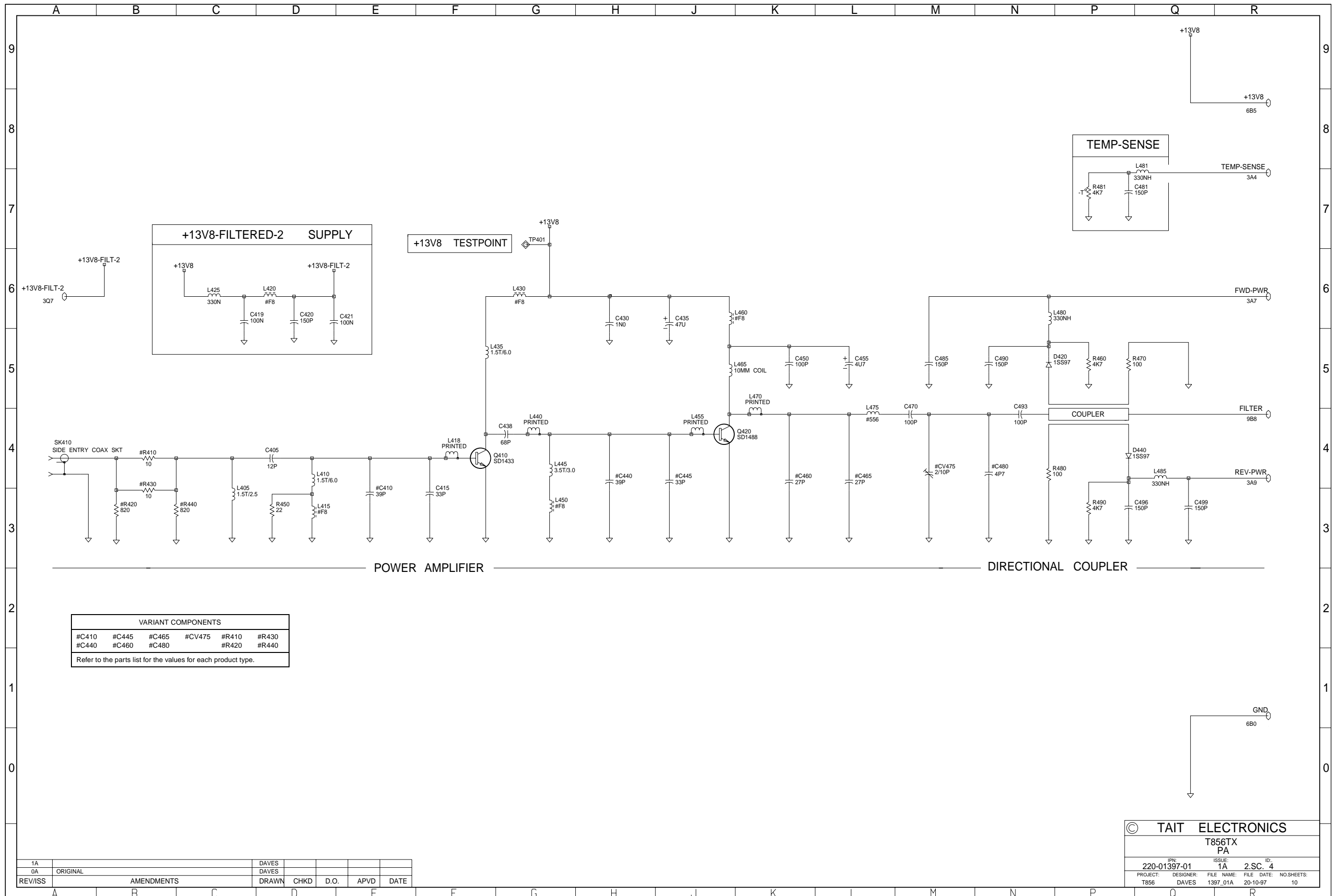

VARIANT COMPONENTS					
#C410	#C445	#C465	#CV475	#R410	#R430
#C440	#C460	#C480		#R420	#R440

Refer to the parts list for the values for each product type.

1A	DAVES				
0A	ORIGINAL	DRAWN	CHKD	D.O.	APVD
REV/ISS	AMENDMENTS				DATE

© TAIT ELECTRONICS
T856TX PA
IPN: 220-01397-01 ISSUE: 1A ID: 2.SC. 4
PROJECT: T856 DESIGNER: DAVES FILE NAME: 1397_01A FILE DATE: 20-10-97 NO. SHEETS: 10

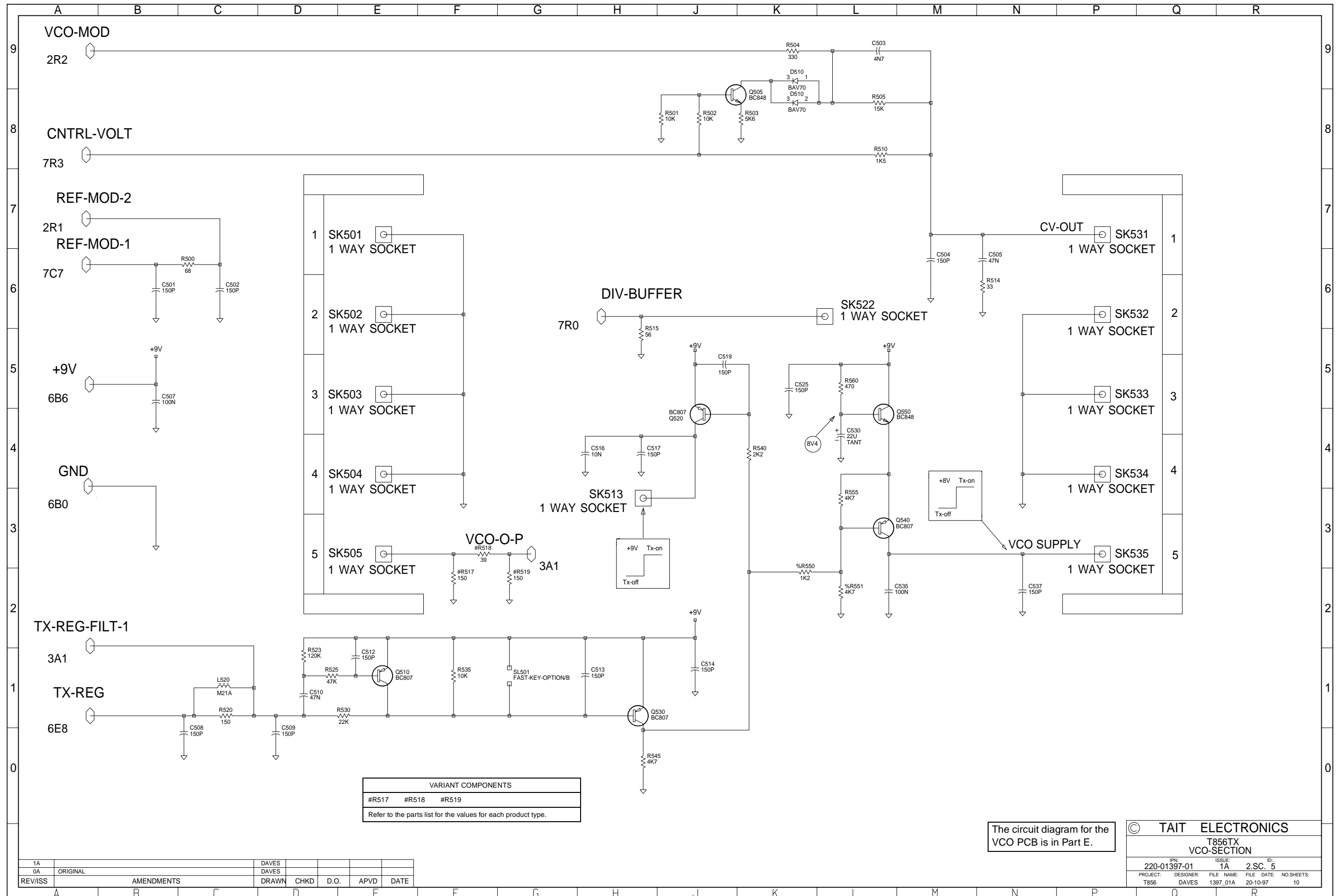

© TAIT ELECTRONICS	
T856TX VCO-SECTION	
IPN: 220-01397-01	ISSUE: 1A
DESIGNER: DAVES	FILE NAME: 1397_01A
DATE: 20-10-97	NO. SHEETS: 10

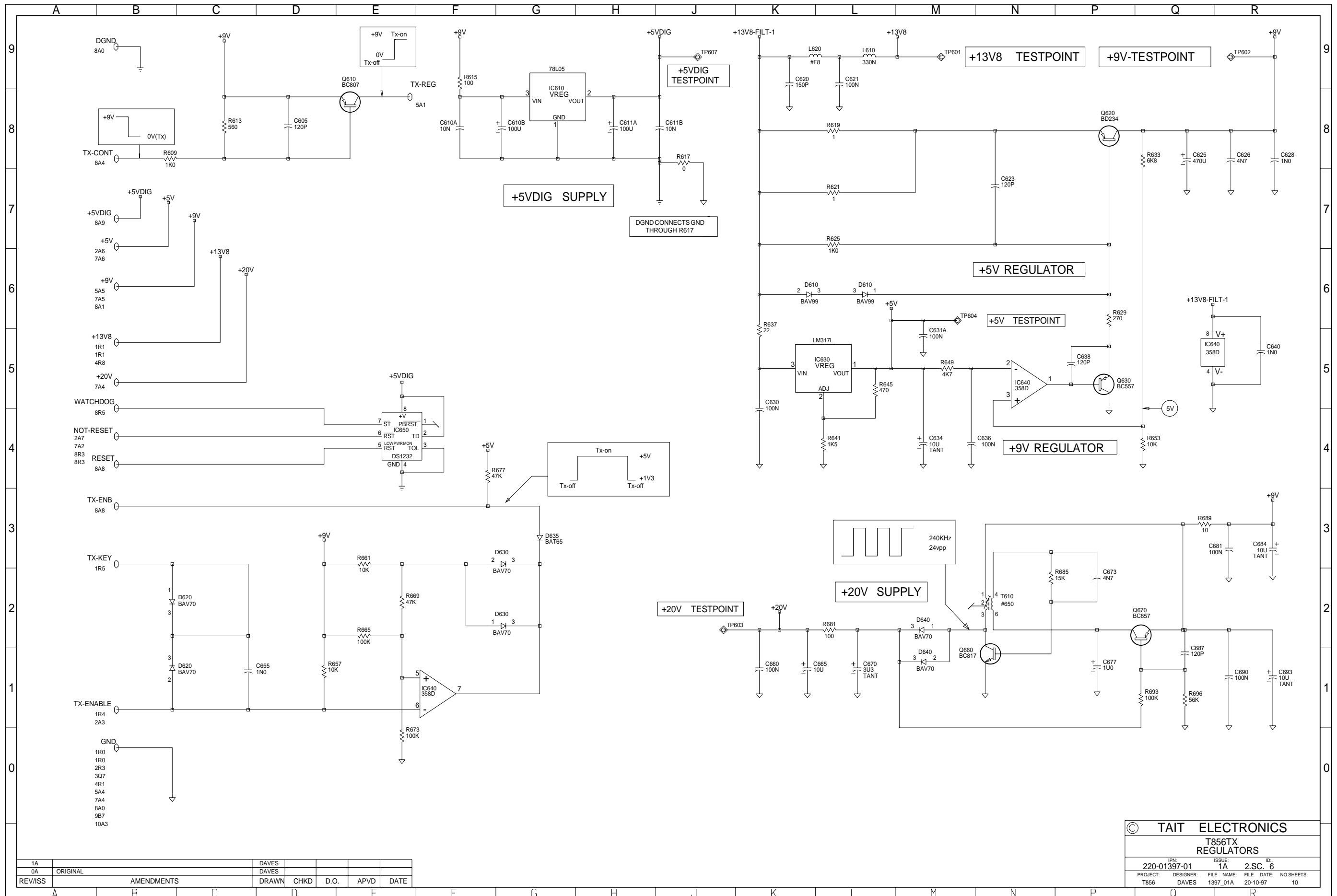

1A	DAVES				
0A	ORIGINAL				
REV/ISS	AMENDMENTS	DRAWN	CHKD	D.O.	APVD
					DATE

© TAIT ELECTRONICS			
T856TX REGULATORS			
IPN:	ISSUE:	ID:	
220-01397-01	1A	2.SC.	6
PROJECT:	DESIGNER:	FILE NAME:	FILE DATE:
T856	DAVES	1397_01A	20-10-97
			NO.SHEETS:
			10

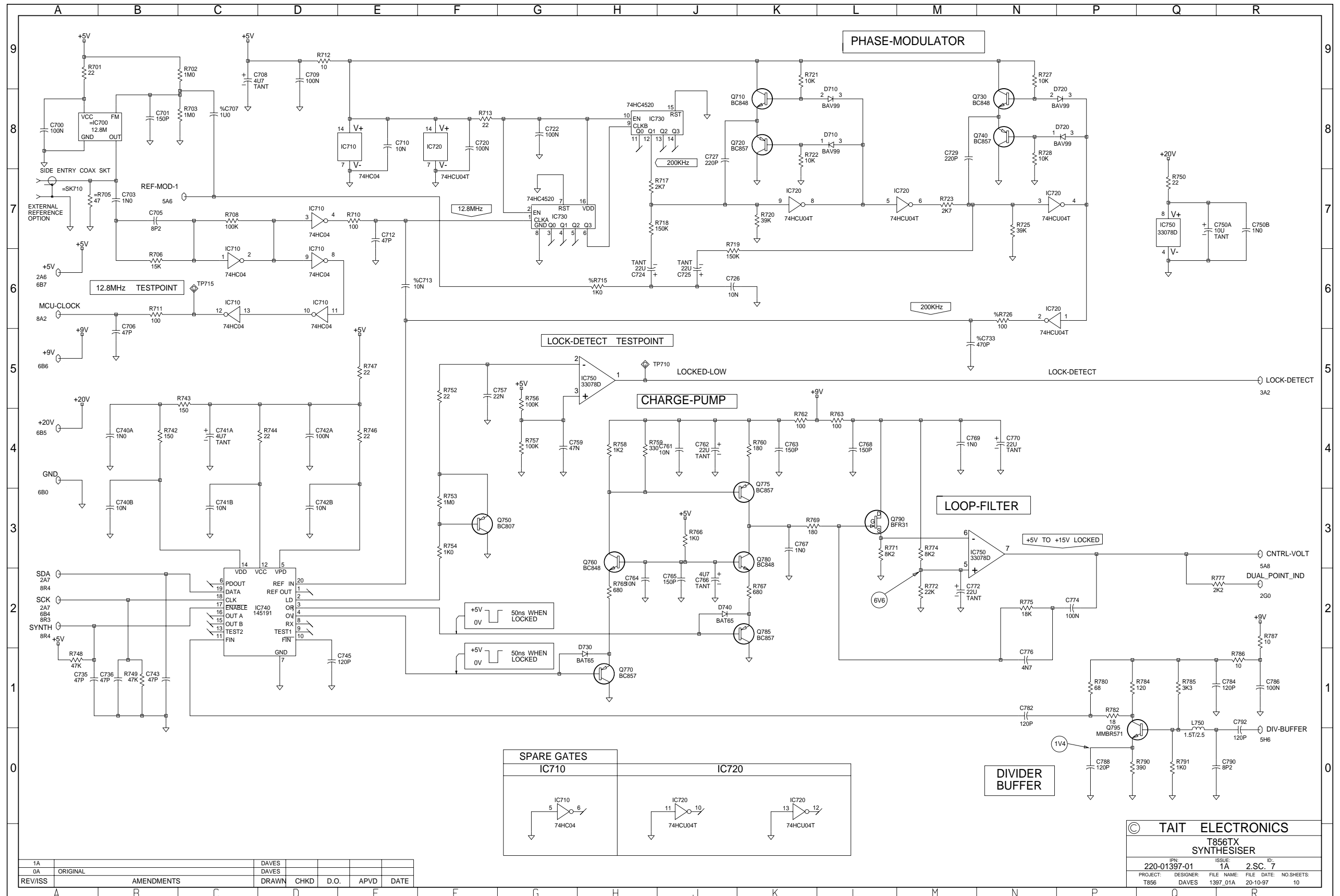

1A		DAVES				
0A	ORIGINAL	DAVES				
REV/ISS	AMENDMENTS	DRAWN	CHKD	D.O.	APVD	DATE

© TAIT ELECTRONICS			
T856TX SYNTHESISER			
IPN:	ISSUE:	FILE:	NO. SHEETS:
220-01397-01	1A	2.S.C. 7	10
PROJECT:	DESIGNER:	FILE NAME:	DATE:
T856	DAVES	1397_01A	20-10-97

